

MANUAL SECTION	ISSUE DATE	AUTHORISED	REPLACES	PAGE
Flooring	August 2009	PM	July 2007	1 of 2

Rapidshield Instantly UV cured , VOC free Floor Coating

Description

Rapidshield is an instantly UV cured floor coating system. The coating is applied to prepared concrete and is cured instantly by passing an intense UV system over its surface. It is the re-coatable immediately.

- Very Low odour, No VOC's
- Non-flammable and may be used in food-safe areas.
- Instantly cured.

TYPICAL USES:

- Industrial, Commercial floor coating & Line marking.
- Food and chemical production areas, where appearance, durability and low maintenance are important as well as **no-downtime installations**
- Concrete repair.
- Approved for use in food manufacturing plants by regulatory authorities.
- Food, Brewing, Canning and general manufacturing areas.
- Dairy Industry – Manufacturing, packing areas.
- Meat Industry – Freezers, chillers and processing areas.
- Pharmaceutical manufacturing.
- Confectionery and chocolate manufacturing.
- Restaurant/hotel kitchens
- Supermarkets - Meat preparation deli areas
- Prisons – Kitchens and ablutions
- Hospitals, Ablution facilities in schools
- Freezers & Chillers – will cure instantly and bond well



Applications:

1. Where floors need instant curing
2. Floor coating in a 24/7 operation
3. Where floors are distant and delays between curing cycles is costly.
4. In chillers and freezers.
5. Where the contractor cannot allow delays
6. Where odours are not tolerated

Maintenance and Cleaning

Repairs can be undertaken with further new Rapidshield applied directly after preparation

Cleaning: Clean during normal cleaning process

No warranty either expressed or implied or statutory is made by NUPLEX in this document except as expressly stated in any sale and purchase agreement entered into between NUPLEX and the buyer. CERTIFIED ISO 9001 REG. NO. 158 This document is a technical data information sheet The description of the product or products and the properties of the product or products contained in this document is for the sole purpose of identifying the product or products and describing their property or properties and does not constitute a warranty that the product or its properties shall conform to that description; nor is the description of the product and/or its properties a warranty by NUPLEX that the goods are suitable for a particular purpose.

Products and Coverage

	Code	Thickness applied	Coats	Coverage
Primer / sealer	QV008 primer	0.065 -0.1mm	1	14m ² /lt
Colours	QV0604 safety yellow	0.065 -0.1mm	2	14m ² / Lt / coat
	QV0304 Light grey	0.065 -0.1mm	2	14m ² / Lt / coat
	QV0404 Quaker Blue	0.065 -0.1mm	2	14m ² / Lt / coat
	UV0202 white	0.065 -0.1mm	2	14m ² / Lt / coat
Topcoat	QV007 clear	0.065 -0.1mm	1	14m ² /lt

Systems as per drawings overleaf

	Primer / sealer	Colours	Topcoat	Number of coats
Dust Seal	Y	N	N	1
Standard clear system	Y	N	Y	2
Line & floor markings	Y	Y x 2	Y	4
Standard coloured floors	Y	Y x 2	Y	4



RapidShield™ Floor coating systems

Various floor coatings are available: numerous colours and thicknesses as well as other appearances. Substrate normally means clean and dry concrete, but RapidShield™ can be applied to other, existing floor types.

Dust seal system

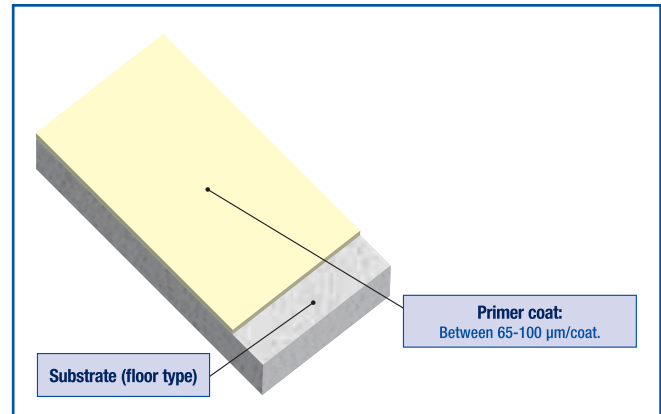

Standard clear system

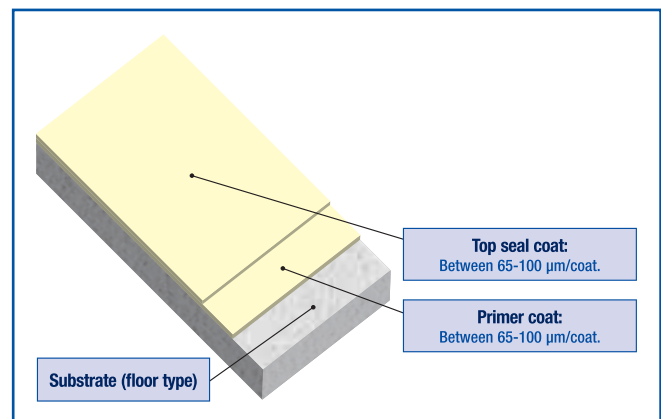

**Special options for clear system:
Lines and Floor Signs**

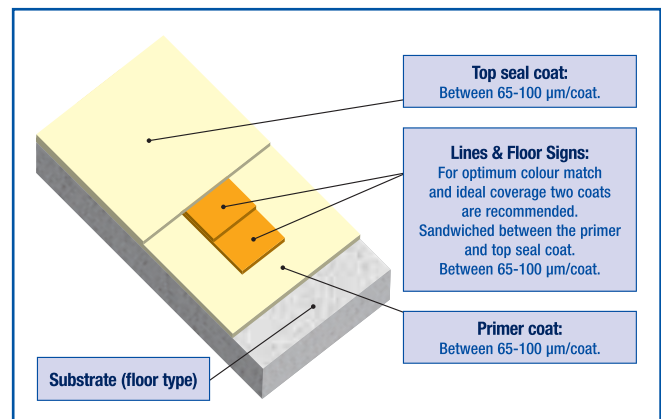

Standard colour system

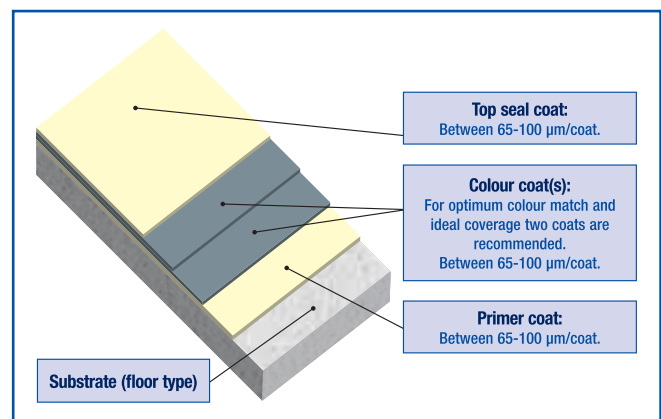

Special options
for colour system:
Lines, Floor Signs
and Anti-skid

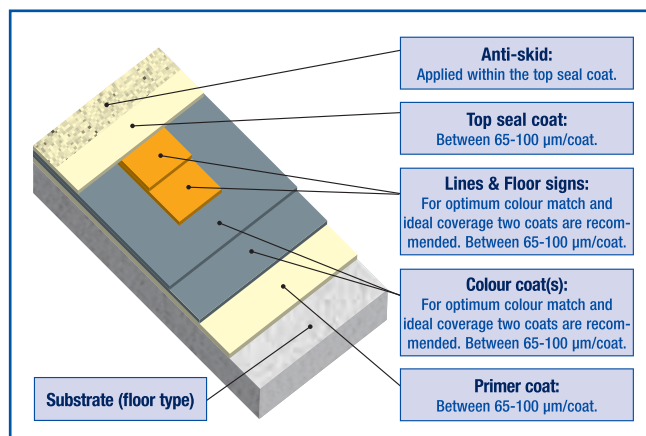

High Build clear system

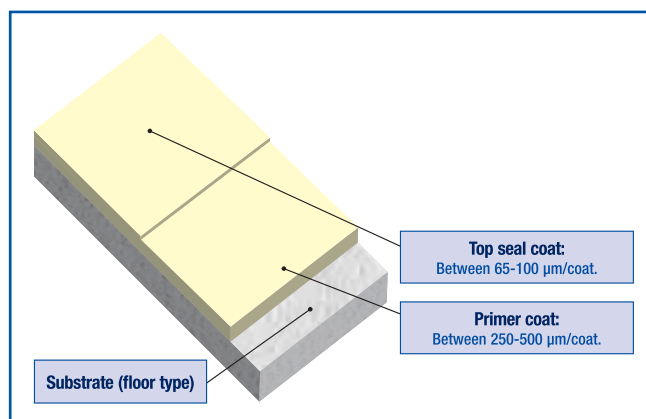

Special options for
High Build clear system:
For uneven floors

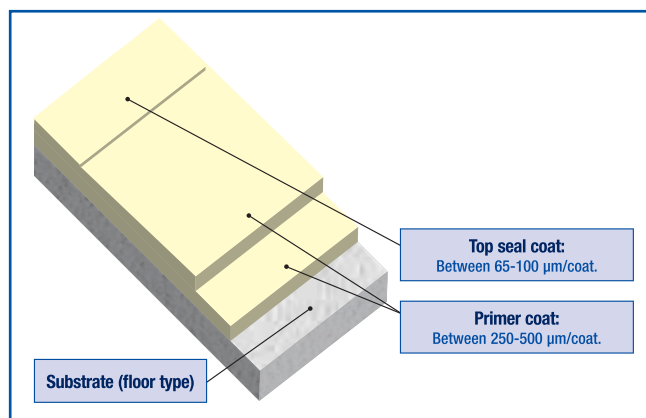

High Build colour system

